

User Manual

OriCell™ RAW 264.7 Mouse

Monocyte Macrophage Leukemia

Cell Line with RFP

Catalog No. M3-0104



Introduction

The RAW 264.7 mouse monocyte macrophage leukemia cell line was originally isolated from tumor tissues of male BALB/c mice induced by the Abelson murine leukemia virus (A-MuLV). This cell line is characterized by its ease of culture and passage, sensitivity to RNA interference (RNAi), and high DNA transfection efficiency, making it a widely used host for transfection studies and a model for murine norovirus (MNV) replication.

The cells are negative for the surface markers slg^- , la^- , and Thy-1.2. It has been reported that the established cell line no longer secretes or contains detectable viral particles. Furthermore, the cell line has tested negative in XC plaque assays and for the presence of the ectromelia virus (mousepox).

OriCell™ RAW 264.7 Mouse Monocyte Macrophage Leukemia Cell Line with RFP is a stable cell line constitutively expressing red fluorescent protein, generated by transducing the parental RAW 264.7 line with a lentiviral vector harboring the RFP gene. This modified line serves as an optimized tool for a wide range of in vivo and in vitro applications requiring precise cellular tracking and visualization.

Note: This product is intended for research use only and is not for diagnostic, therapeutic, clinical, household, or any other applications.

When citing our products in academic publications, please use the following format: “OriCell™ [Product Name] + [Catalog Number], from Cyagen Biosciences.”

Expression Vector

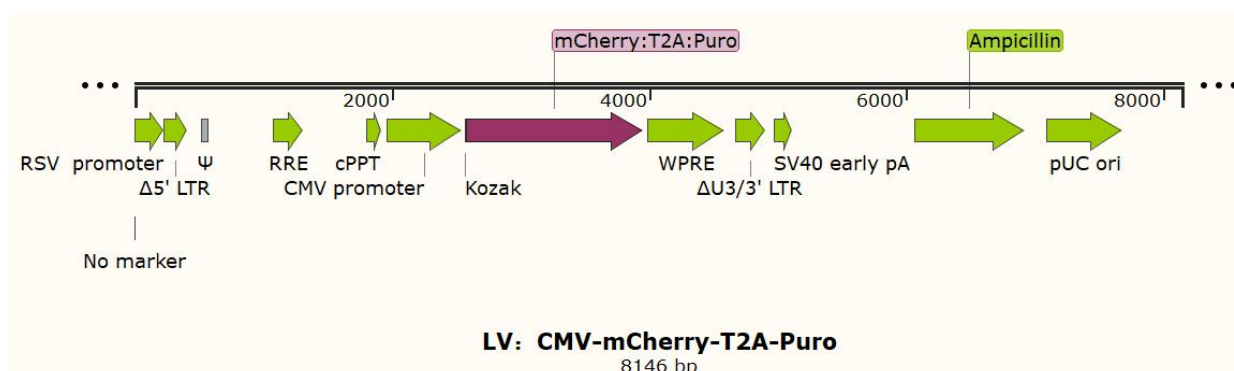

Product Information

Product Name	OriCell™ RAW 264.7 Mouse Monocyte Macrophage Leukemia Cell Line with RFP
Alternative Name	RAW 264.7 with RFP
Catalog Number	M3-0104
Amount of Cells	1×10 ⁶ cells/vial
Tissue Origin	Mouse Ascites
Cell Characteristics	Adherent Growth; Macrophage-like
Culture Conditions	95% air; 5% CO ₂ ; 37 °C
Culture Medium	DMEM + 10% FBS
Doubling Time	12 ~ 24 h
Biosafety Level	2
Storage at	Liquid Nitrogen (-196 °C)
Precautions	Avoid using trypsin. It is recommended to use culture dishes and high-quality serum.
Tips	Fluorescence Selection: If RFP fluorescence is weak, add puromycin (0.5–2 μg/mL) for 2–4 days every 3–5 passages. Stop selection once fluorescence visibly increases.

Note: This product is manufactured under strict aseptic conditions. You may choose to add antibiotics during subsequent culturing based on your specific needs.

The Morphology of OriCell™ RAW 264.7 Cell Line with RFP

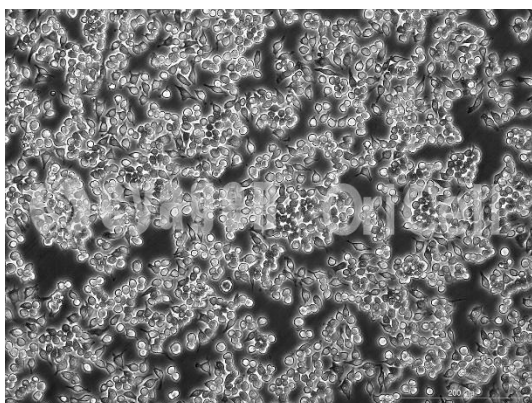

QC

- Pass the detection of bacteria, fungi, mycoplasma, and endotoxins.
- Verified by cell recovery testing.
- Verified by STR analysis.

Please refer to "COA" for details.

General Handling Principles

1. Maintain strict aseptic technique. Ensure complete sterility throughout all procedures, particularly within the laminar flow hood and incubator.
2. Follow standardized protocols. Adhere strictly to the product manual. Implement rigorous control over experimental variables and include appropriate parallel controls.

- Use high-quality consumables and reagents. This product requires culture vessels suitable for adherent growth, and the reuse of these vessels is not recommended. The reagents used must be validated for reliability, cell compatibility, and batch-to-batch consistency.

Note: The cryopreservation medium of this product contains DMSO, which may pose potential risks.

Please handle it with care.

Abbreviation	Name	Cat. No.
FBS	Fetal Bovine Serum	See official website
BCS	Bovine Calf Serum	SBCST-01001
Glu	Glutamine	SGLU-10201
SP	Sodium Pyruvate	SCSP-10301
Dex	Dexamethasone	SDEX-10401
NBCS	Newborn Calf Serum	NCSST-01001
HS	Horse Serum	SCHST-01001
NEAA	Non Essential Amino Acid	NEAA-10201
β-mer	β-mercaptoethanol	BMER-10301
P/S	Penicillin- Streptomycin	ATPS-10001
ITS	Insulin / Transferrin / Selenite	ITSS-10201

Thawing and Culturing of Cells

Materials Required

- OriCell™ RAW 264.7 Mouse Monocyte Macrophage Leukemia Cell Line with RFP (Cat. No.: M3-0104)
- OriCell™ Complete Medium For RAW 264.7 Cell Line (Cat. No.: CMM3-0101)

Steps

Note: If thawing is planned within 24 hours of receipt, store the cells in an ultra-low temperature freezer at -80 °C. For long-term storage (>24 hours), keep them in liquid nitrogen. Before thawing, transfer the cells from liquid nitrogen to -80 °C and hold them there for 10 minutes. This will allow any residual liquid nitrogen to evaporate and prevent vial explosion.

1. Pre-warm the water bath to 37 °C.
2. Warm the complete medium to 37 °C.
3. Add at least 5 mL of pre-warmed complete medium to a 15 mL centrifuge tube for subsequent use.
4. Remove the cryovial containing cells from the -80 °C freezer, immerse it in the 37 °C water bath, and gently and quickly swirl to thaw the cryopreservation medium.

Note:

(1) Gently swirl the cryovial during thawing to ensure rapid and uniform thawing.

(2) Avoid submerging the cap in water to prevent contamination.

(3) Stop thawing in the water bath when only a single ice crystal (approximately 2 mm in diameter) remains, then continue gently swirling the vial until it is completely thawed.

5. Wipe the outer surface of the cryovial with 75% ethanol.
6. In a biosafety cabinet, open the cryovial and transfer the cell suspension to the prepared centrifuge tube using a Pasteur pipette.
7. Rinse the cryovial once with 1 mL of complete medium to collect residual cells and minimize loss.
8. Centrifuge the cell suspension at 250 × g for 4 minutes.

Note: Please calculate the corresponding rotational speed using the formula: $RCF = 1.118 \times 10^{-5} \times r \times RPM^2$ (where RCF is the relative centrifugal force, r is the rotor radius in cm, and RPM is the rotational speed).

9. Carefully remove the supernatant after centrifugation. Add 2 mL of pre-warmed complete medium, gently resuspend the cell pellet by pipetting up and down to mix thoroughly.
10. Seed the cells into a 6 cm culture dish or culture vessel with an equivalent growth surface area. Add sufficient complete medium so that the total volume in a 6 cm culture dish is no less than 4 mL.

Note: It is recommended to use culture dishes for recovery, passaging, and routine culture. The cells exhibit limited differentiation and are easy to passage.

11. Gently swirl the culture dish to evenly distribute the cells, then incubate in a CO₂ incubator at 37 °C with 5% CO₂ and saturated humidity.

Note: Do not move or observe the cells within the first 2 hours after seeding, as this may impair cell adhesion, causing poor morphology, clumping, and uneven attachment.

12. On the day after recovery, observe cell status and either replace the medium with fresh complete medium or passage the cells as needed.

Note: If an excessive number of floating cells or any abnormal conditions are observed, investigate promptly and contact us for assistance.

13. Replace the complete medium every 3 days until the cells reach approximately 85% confluence, at which point they are ready for passage.

Passaging of Cells

Materials Required

- OriCell™ Phosphate-Buffered Saline Solution (1X) (Cat. No.: PBS-10001)
- OriCell™ Complete Medium For RAW 264.7 Cell Line (Cat. No.: CMM3-0101)

Steps

Note: Under standard culture conditions and in the absence of induction, RAW264.7 cells primarily exhibit two morphologies: loosely adherent spindle-shaped cells and round or cuboidal cells. As cell density increases, some adherent cells undergo morphological changes, characterized by cell body retraction, rounding, or the formation of cell aggregates. Some of these cells may detach and become suspended in the medium. It is important to note that these suspended cells remain biologically active and should be retained during passaging. They can be collected by centrifugation at $250 \times g$ for 4 minutes, and the resulting cell pellet can be resuspended and used for subsequent culture.

1. Aspirate and discard part of the supernatant using a pipette, leaving a small amount (e.g., 2–3 mL for a 6 cm dish) in the culture dish to facilitate gentle pipetting.

Note: If a large number of suspended cells are observed under the microscope, collect the entire supernatant and centrifuge it together with the detached cells to avoid cell loss.

2. Using a 1 mL disposable pipette tip or a serological pipette, aspirate and dispense the remaining supernatant repeatedly against the bottom surface of the culture dish to detach the cells.

Note: Avoid vigorous pipetting to prevent excessive bubble formation, which may damage the cells. Differentiated cells that remain firmly attached after gentle pipetting should be discarded.

3. Transfer the cell suspension to a 15 mL centrifuge tube.
4. Rinse the culture dish with PBS (approximately 3 mL for a 6 cm dish or 6 mL for a 10 cm dish) to collect any remaining cells, then add the wash to the centrifuge tube.
5. Centrifuge all collected cell suspensions at $250 \times g$ for 4 minutes.
6. Carefully remove the supernatant after centrifugation. Add 2 mL of complete medium to the

15 mL centrifuge tube and gently resuspend the cell pellet by pipetting up and down to thoroughly mix.

7. Seed the cells into a suitable culture vessel at a density of $(4-6) \times 10^4$ viable cells/cm², or adjust the seeding density based on the actual growth conditions of the cells.

Note: We recommend manual cell counting when conditions permit and counting efficiency is high, in order to obtain an accurate cell concentration to guide seeding. If precise counting is not feasible, subculturing at an appropriate ratio is a reliable alternative. Typically, RAW 264.7 cells with RFP are passaged at a ratio of 1:3 to 1:6, with cells reaching passage confluence within 48 hours. Please adjust the subculture ratio according to the actual condition of the cells.

8. Gently agitate the vessel to ensure uniform cell distribution and place it in an incubator at 37 °C, 5% CO₂, and saturated humidity.
9. On the day after passaging, observe the cell condition. If a significant number of floating cells are present and the cells appear to be in poor condition, replace the culture medium.
10. Replace the culture medium every 3 days. When cells reach 85% confluence, passage or cryopreserve the cells.

Cryopreservation of Cells

Materials Required

- OriCell™ NCR Protein-Free Cryopreservation Medium For General Use (Cat. No.: NCPF-10001)
- OriCell™ NCR Cryopreservation Medium For General Use (Cat. No.: NCRC-10001)

Steps

1. Cells should be cryopreserved once they reach an appropriate density suitable for passaging.
2. For cell collection, please refer to passaging steps 1-5 above.
3. Carefully remove the supernatant after centrifugation and gently resuspend the cells in an appropriate volume of cryopreservation medium.
4. Aliquot the cells into cryovials according to the desired cell number or proportion.

Note: If accurate cell counting is not feasible, we recommend aliquoting cells proportionally for freezing. Prolonged exposure to non-culture conditions will significantly compromise cell viability. Maintain the cells at 4 °C during counting to minimize metabolic activity and preserve cell integrity.

5. When using any of the recommended NCR cryopreservation media above, cryovials can be directly placed individually into a -80 °C freezer.

Note: Avoid opening the freezer door during the first 4 hours of freezing, as temperature fluctuations can adversely affect cell viability.

6. After approximately 8 hours, transfer the cryovials to liquid nitrogen for long-term storage.

Note: Do not store the cryovials at -80 °C for more than 48 hours.

Cyagen Biosciences (Suzhou) Inc. reserves all rights to the technical documents of OriCell™ cell culture products. Without the written permission of Cyagen Biosciences (Suzhou) Inc. any part of this document shall not be adapted or reprinted for other commercial purposes.